

MB20J/MB26J

MAST BOOM LIFTS

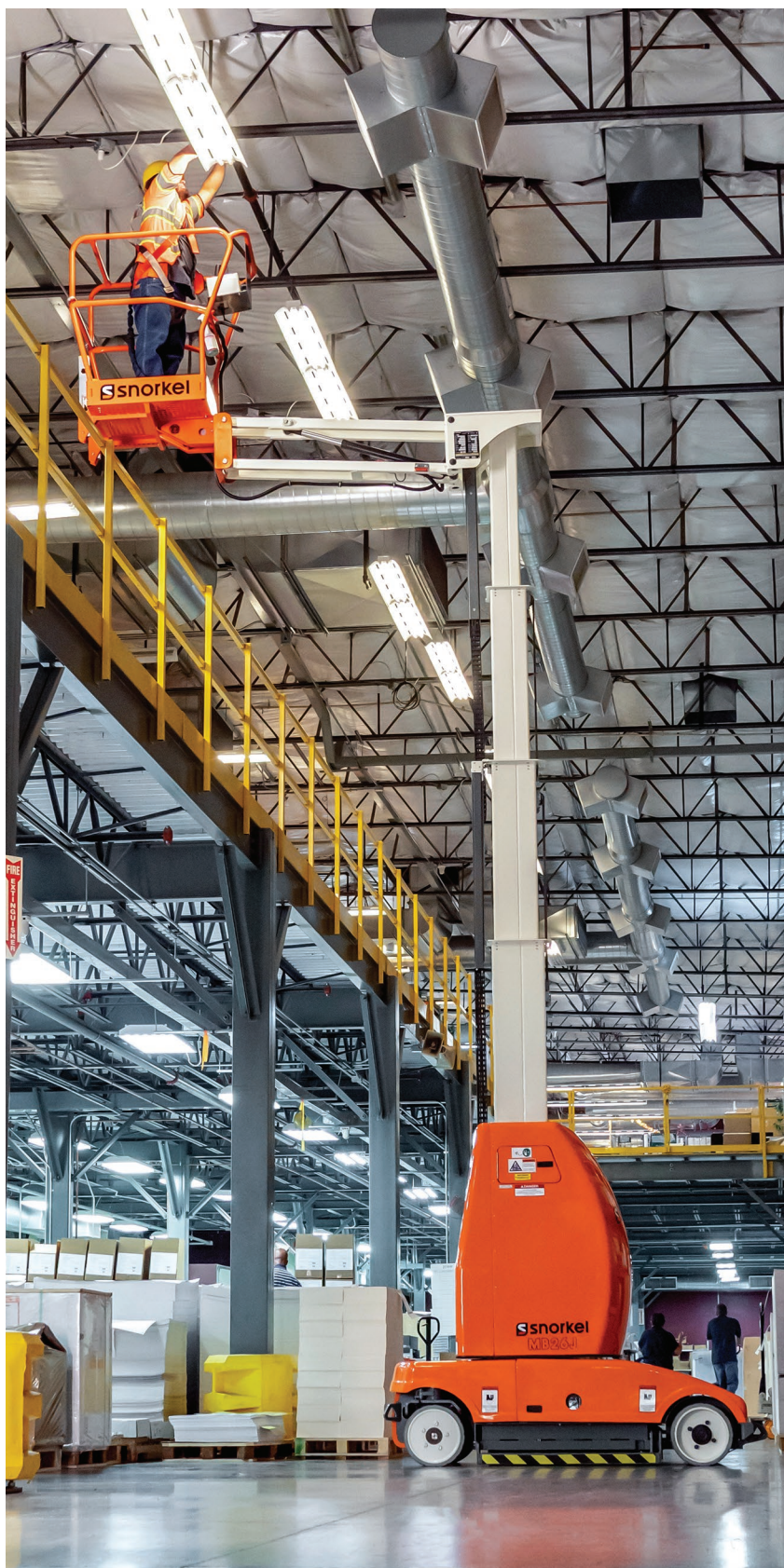

- Versatile electric mast booms
- Ultra-narrow for use in confined spaces
- Superb working envelope including "up & over" capabilities
- Simple to operate and maintain
- Ideal for retail & warehouse applications

 **snorkel**™
www.snorkellifts.com

MAST BOOM LIFTS

MB20J/MB26J

DIMENSIONS	MB20J	MB26J
Max. working height	26 ft	31 ft 6 in
Max. platform height	20 ft	25 ft 6 in
Max. horizontal reach	8 ft 6 in	9 ft 10 in
Platform size	30 in x 28 in	30 in x 28 in
Overall width (A)	32 in	39 in
Overall length (C)	7 ft 11 in	9 ft 2 in
Stowed height (B)	6 ft 6 in	6 ft 6 in
Ground clearance	4 in	4 in

PERFORMANCE	MB20J	MB26J
Platform capacity (SWL)	475 lbs	475 lbs
Max. wind speed	28 mph	28 mph
Max. drive height	20 ft	20 ft
Max. drive speed (stowed)	2.0 mph	2.0 mph
Max. drive speed (elevated)	0.3 mph	0.3 mph
Jib length	3 ft 4 in	4 ft 7 in
Jib arc	130°	130°
Mast rotation (non-continuous)	360°	360°
Raise/lower time	54/26 seconds	56/27 seconds
Gradeability	25%	25%
Inside turning radius	11 in	11 in
Outside turning radius	6 ft	6 ft 10 in
Tires	13.5 x 4 non-marking rubber	
Controls	proportional controls	
Drive system	electro/hydraulic	

POWER	MB20J	MB26J
Power source	4 x 6V 375 Ah batteries	

WEIGHT	MB20J	MB26J
Weight	6,675 lbs	7,000 lbs

WORKING ENVELOPE

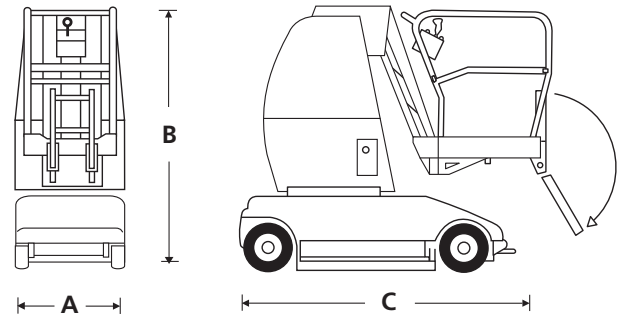
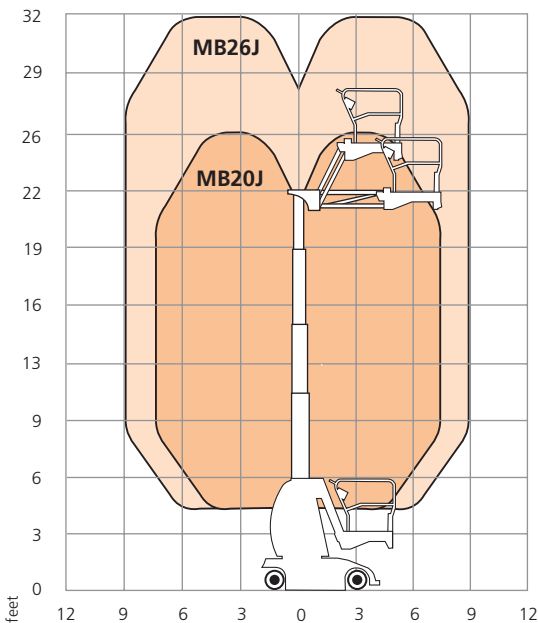

STANDARD FEATURES

- Ultra-tight inside turning radius
- Proportional controls
- Tilt alarm
- Non-marking tires
- 2 persons indoor
- 1 person outdoor
- Self-seeking automatic battery charger
- Automatic battery fill
- Power line to platform
- Hour meter & on-board diagnostics display
- Hydraulic pothole protection system
- 2 year parts & labor, 5 year structural warranty
- ANSI compliant

OPTIONS

- Special paint colors
- Flashing amber light
- Environmental hydraulic oil



P.O. Box 1160
 St. Joseph, MO 64502-1160, USA
 Tel: 1 (785) 989-3000
 Toll-free: 1 (800) 255-0317
 Fax: 1 (785) 989-3070
 Email: sales.usa@snorkellifts.com

www.snorkellifts.com