

TECHNICAL DATA

TANDEM ROLLERS

BW 900-50

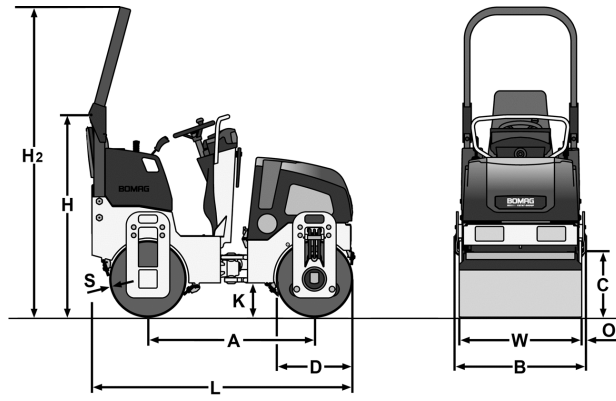



Dimensions in inch

	A	B	C	D	H	H2	K	L	O	S	W
BW 900-50	48.1	37.8	17.7	22.0	68.0	90.2	9.8	77.4	1.2	0.31	35.4

Shipping dimensions in cub.yd

BW 900-50

without ROPS

4.263

with ROPS

6.408

Machine type	Compaction output (cub.yd/h) at recommended soil layer thicknesses		
	Gravel, sand	Mixed soil	Silt, clay
BW 900-50	65.4-130.8	45.8-91.6	39.2-71.9

Machine type	Compaction output (t/h) at different asphalt layer thicknesses		
	2-4 in	6-8 in	10-14 in
BW 900-50	13.1-32.7	26.2-52.3	39.2-78.5

Technical Data**BOMAG
BW 900-50****Weights**

Operating weight CECE	lb	2,646
Average axle load CECE	lb	1,321
Average static linear load CECE	lb/in	37.3

Dimensions

Working width	in	35.4
Track radius, inner	in	64.8

Driving Characteristics

Working speed with vibration	mph	0- 2.5
Max. travel speed	mph	0- 5.4
Max. gradeability without/with vibr.	%	40/30

Drive

Engine manufacturer		Honda
Type		GX 630
Cooling		air
Number of cylinders		2
Performance ISO 9249	hp	20.0
Performance SAE J 1995	hp	20.0
Speed	rpm	3,300
Electric equipment	V	12
Drive system		hydrost.
Driven drum		2

Brakes

Service brake		hydrost.
Parking brake		mech.

Steering

Steering system		oscil.artic.
Steering method		hydrost.
Steering angle +/-	deg	33
Oscillating angle +/-	deg	6.0

Exciter system

Vibrating drum		front
Drive system		hydrost.
Frequency	vpm	70
Amplitude	in	0.020
Centrifugal force	lb	3,372

Sprinkler System

Type of sprinkling		pressure
--------------------------	--	----------

Capacities

Fuel	gal	7.1
Water	gal	36.2

Technical modifications reserved. Machines may be shown with options.

Standard Equipment

- Hydrostatic travel and vibration drive
- Travel drive in series
- Front drum vibration
- Vibration control in travel lever
- Oscillating artic. center joint
- Hydrostatic articulated steering
- Mechanical parking brake
- 2 scrapers per drum
- Plastic water tank
- Pressure sprinkler system
- Hour meter
- Low fuel level indicator
- Control and warning indicator lights
- Automatic shutdown at low oil level
- Lockable anti vandal dashboard protection
- Seat belt
- Single point lifting device
- Transport lashing and lifting points
front/rear
- Lockable engine cover
- Emergency engine shut down
- Corrosion and weather protected ignition
switch
- Back-up alarm
- Foldable ROPS

Optional Equipment

- ROPS
- Working lights front and rear

